

4

3

2

1

SET GPIO 4-7 LOW TO TURN ON RELAYS
NEW REVISION WITH 'U2' INVERTER

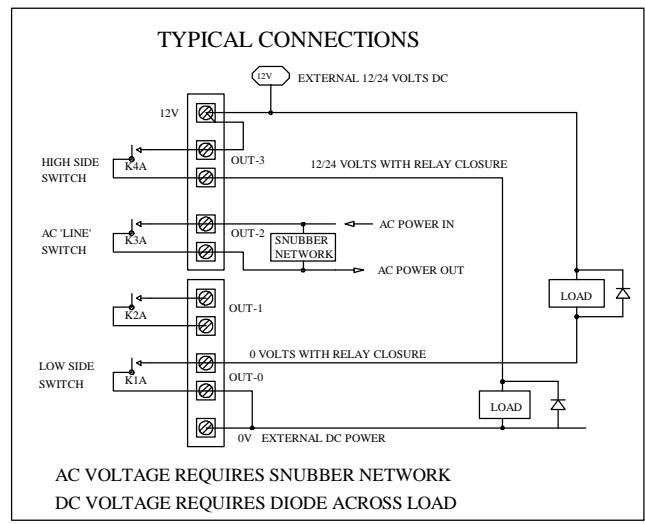
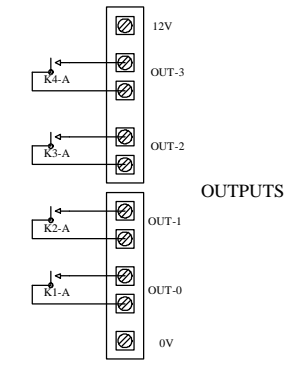
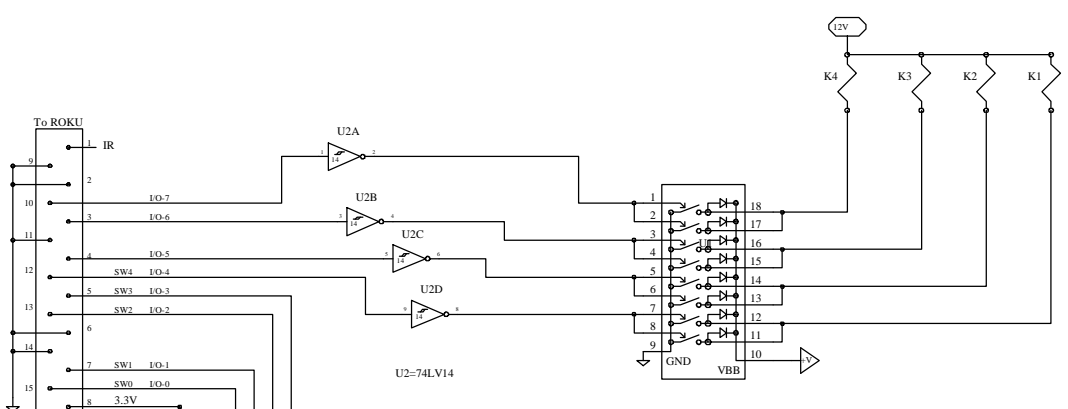
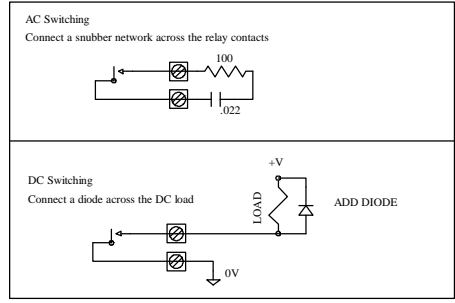
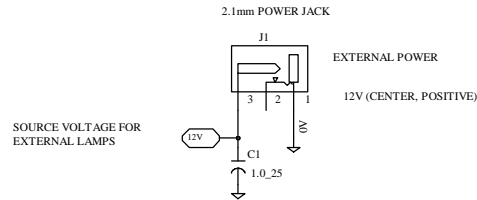

Comp	HMS ELECTRONICS	
Rev	HD_4X4R_S.DBF	
Name	ROKU HD INTERFACE BOARD 4 INPUT, 4 RELAY OUTPUTS	
Org	04-18-14	Rev 2.0
Engineer	Richard Harkey	HMS Electronics

4

3

2

1